

**Range:** Deck-mounted mixer sensor tap

**Ref:** 55377 - PRESTO NOVA

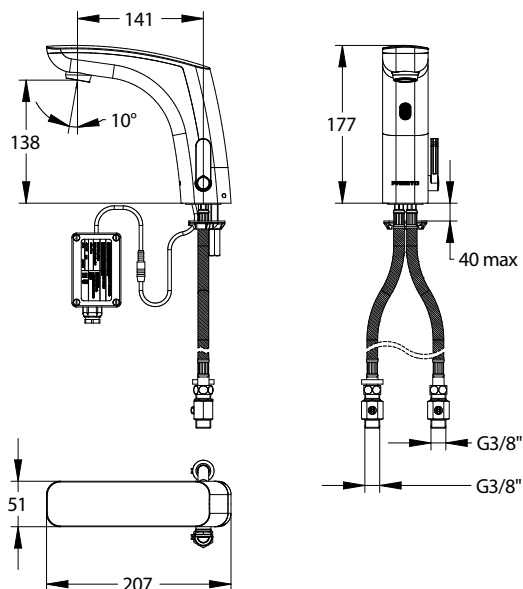

#### > Working pressure :

- 1 to 5 bar

#### > Flow :

- 3 l/min with integrated flow limiter
- High quality anti-limescale aerator
- Anti-water-hammering design

#### > Hydraulic supply :

- G 3/8" (12x17)

#### > Power supply :

- 230 VAC / 7 VDC transformer in IP65 waterproof case

#### > Material and colour finish :

- Injected molded metal body and cover
- Chrome finishing

#### > Thermal resistance :

- Resistant to a temperature of 75°C for 30 minute thermal shocks

#### > Security :

- Temperature limiting system to avoid any risk of scalding
- Anti-overflow security time is set to 30 seconds
- Anti-blocking system preventing the water to flow continuously

#### > Delivered with :

- 1 Brass clamping nut
- 1 Gasket and 1 Washer
- 2 PEX Hoses with revolving nuts and NF check valves
- 2 MM G 3/8" (12x17) Stop valves
- 2 Filter gaskets
- 1 Self-adhesive sticker
- Instruction manual

#### > Standards & approvals :

- Molded chrome-plated body in accordance with EN 12540
- Brass in accordance with NF EN1982, EN12164, EN12165
- 200-hour neutral salt spray resistant (NSS) in accordance with NF ISO 9227

